

SEZIONE TRASVERSALE TIPO ELEMENTI SCATOLARI PREFABBRICATI IN C.A.V. CON GIUNTO A BICCHIERE ED ANELLO DI TENUTA IN GOMMA SINTETICA
Scala 1:50

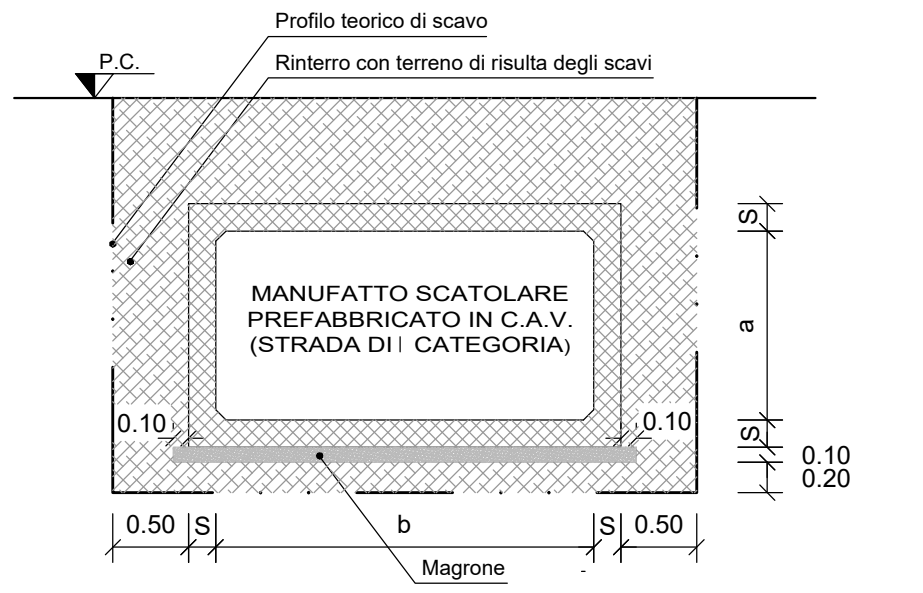

CARATTERISTICHE DIMENSIONALI DEGLI ELEMENTI:		
b (cm):	a (cm):	s (cm):
250	125	18

PARTICOLARE GIUNZIONI ELEMENTI SCATOLARI
Scala 1:10

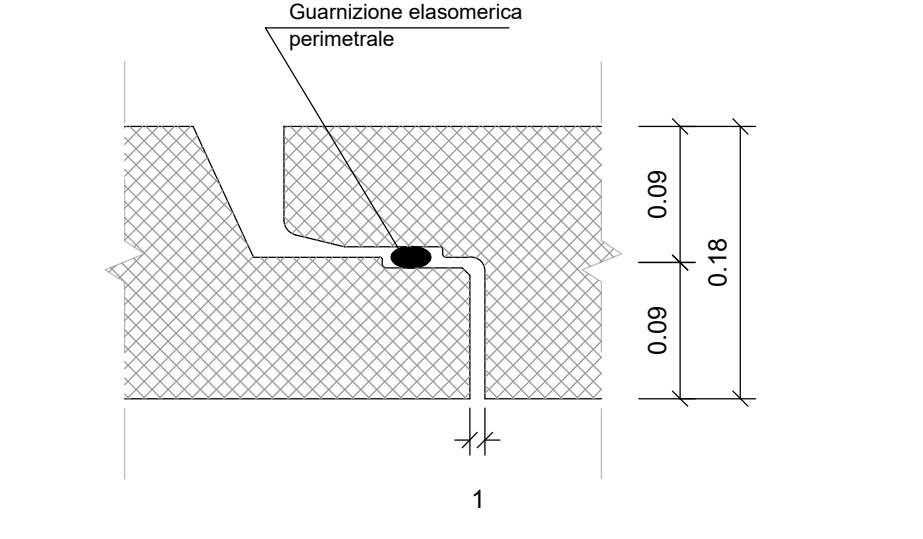

PARTICOLARE DRENAGGIO FONDO SEZIONE Z-Z
Scala 1:10

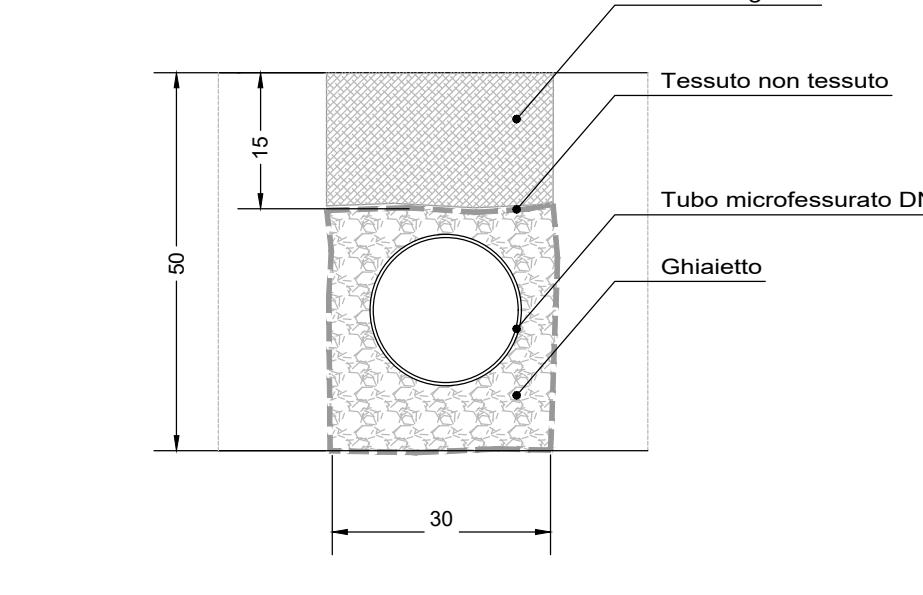

PARTICOLARE SEZIONE C-C
Scala 1:50

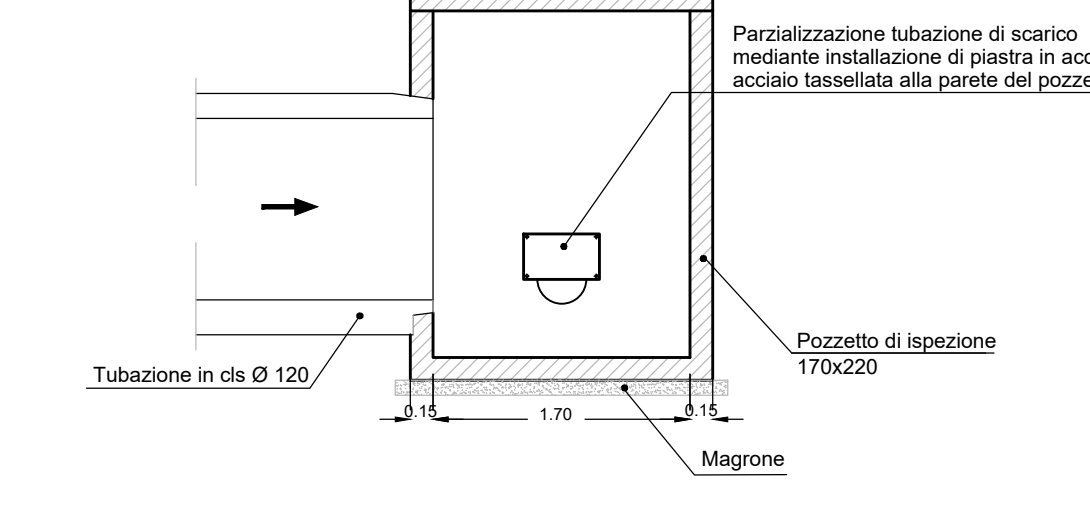

PARTICOLARE "A"
Scala 1:50

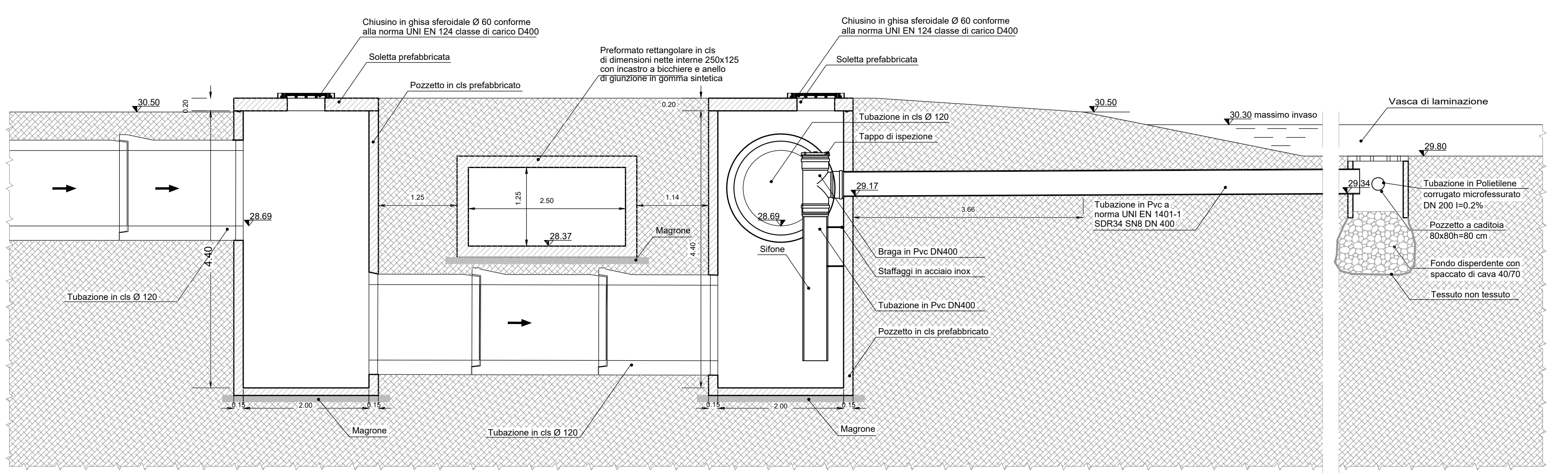

PARTICOLARE SEZIONE A-A VASCA DI LAMINAZIONE- BACINO 2
Scala 1:50

